

PARTS LIST			
ITEM	PART No	DESCRIPTION	QTY
1	AA0409	CONNECTOR IMPULSE MCBH-2-MP-SS	1
2	AA7426	VALVE RELIEF 30psi (3/4"NPT)	1
3	AC9794	HOUSING UPPER - 6L COMPENSATOR	1
4	AC9795	FLANGE COUPLING UPPER - 6L COMPENSATOR	1
5	AC9796	FLANGE COUPLING LOWER - 6L COMPENSATOR	1
6	AC9797	HOUSING LOWER - 6L COMP	1
7	AC9798	BASE PLATE - 6L COMPENSATOR	1
8	AC9799	DIAPHRAGM - 6L COMPENSATOR	1
9	AC9800	TIE BAR - 6L COMP	6
10	AD0213	HOUSING TRANSDUCER	1
11	AD0293	CAP PLATE SENSOR HOUSING	1
12	AD0541	SEAL O-RING 41.5 x 3.0 NBR70	1
13	AD0710	PISTON - 6L COMPENSATOR	1
14	AD0713	RETAINER DIAPHRAGM - 6L COMPENSATOR	1
15	AD0733	TOP PLATE - 6L RESERVOIR	1
16	AD1227	SEAL O-RING / 6.99 x 196.22	2
17	AD5734	SENSOR LJW 0220 N 0.3H S 1994	1
18	AJ7205	LABEL CURVETECH LOGO (BLACK ON TRANSPARENT)	2
19	AJ7481	LABEL WARNING SPRING UNDER COMPRESSION	1
20	AJ8833	LABEL 6L COMPENSATOR LEVEL	2
21	OB_1044	BOLT M10 x 25 SHCS SS A2-70	4
22	PA0078	NUT M6 NYLOC SS A2-70	24
23	PA0192	BOLT M6 x 25 SHCS SS A2-70	4
24	PA0546	WASHER M6 FLAT BS4320 FORM B SS A2	36
25	PB2187	SEAL O-RING BS219 NBR90 1"SAE	1
26	PB7913	SEAL O-RING 84.3 x 5.7	1
27	PB9837	BOLT M6 x 60 SHCS SS A2-70	12
28	PE1755	SEAL O-RING 74.5 X 3.0	1
29	PH3298	CLAMP SPLIT FLANGE 1" SAE3000 SS	1
30	VE_3092-1	SPRING 2-12 PSI - 6L COMPENSATOR	1

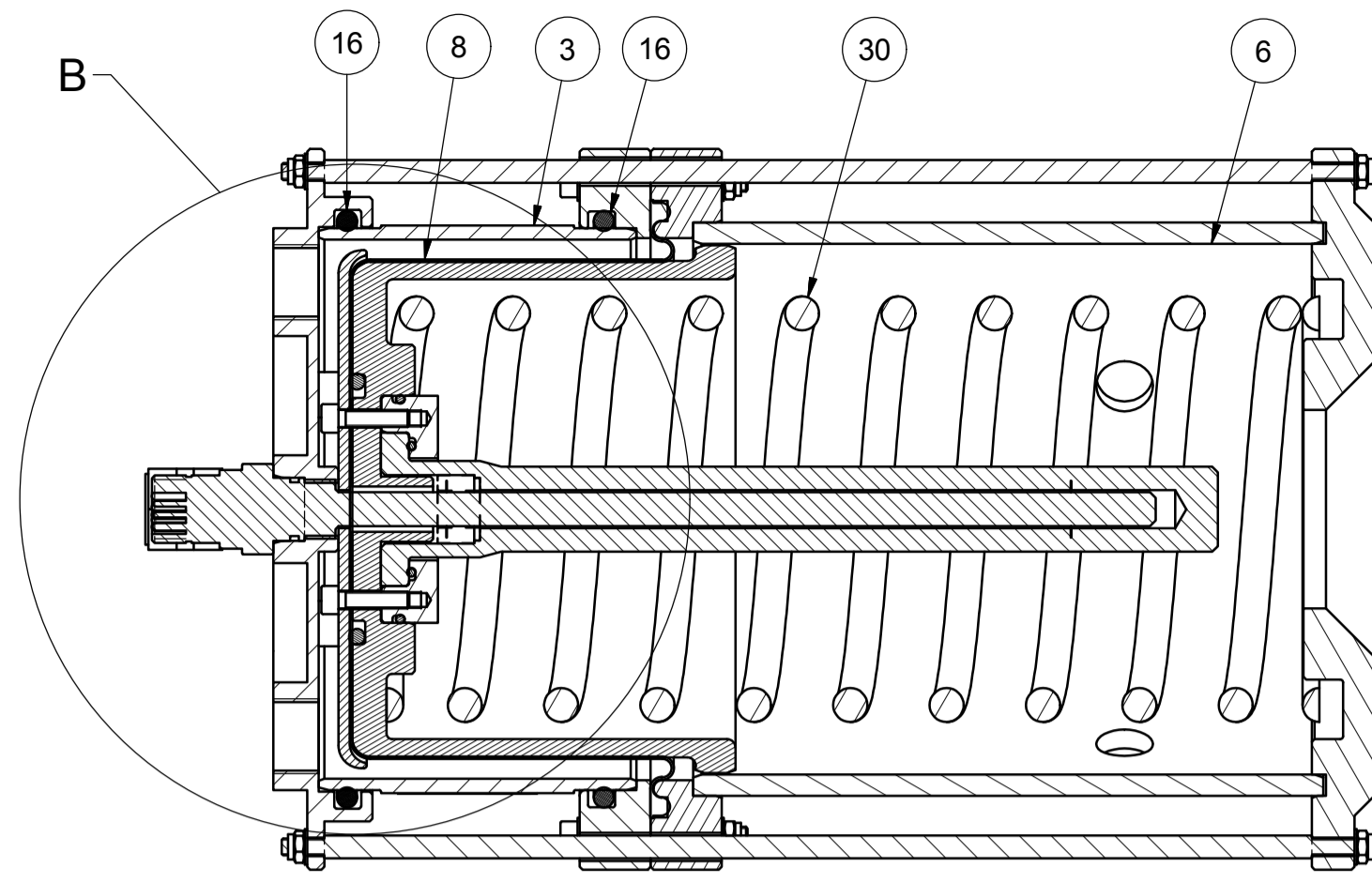

SECTION A-A

WARNING ! DANGER OF INJURY.

CARE MUST BE TAKEN WHEN FITTING OR REMOVING SPRING.
A HYDRAULIC PRESS WITH RELEVANT SAFETY FEATURES OR SMD COMPRESSION TOOL (AJ7395) SHOULD BE USED TO COMPRESS OR RELEASE THE SPRING.

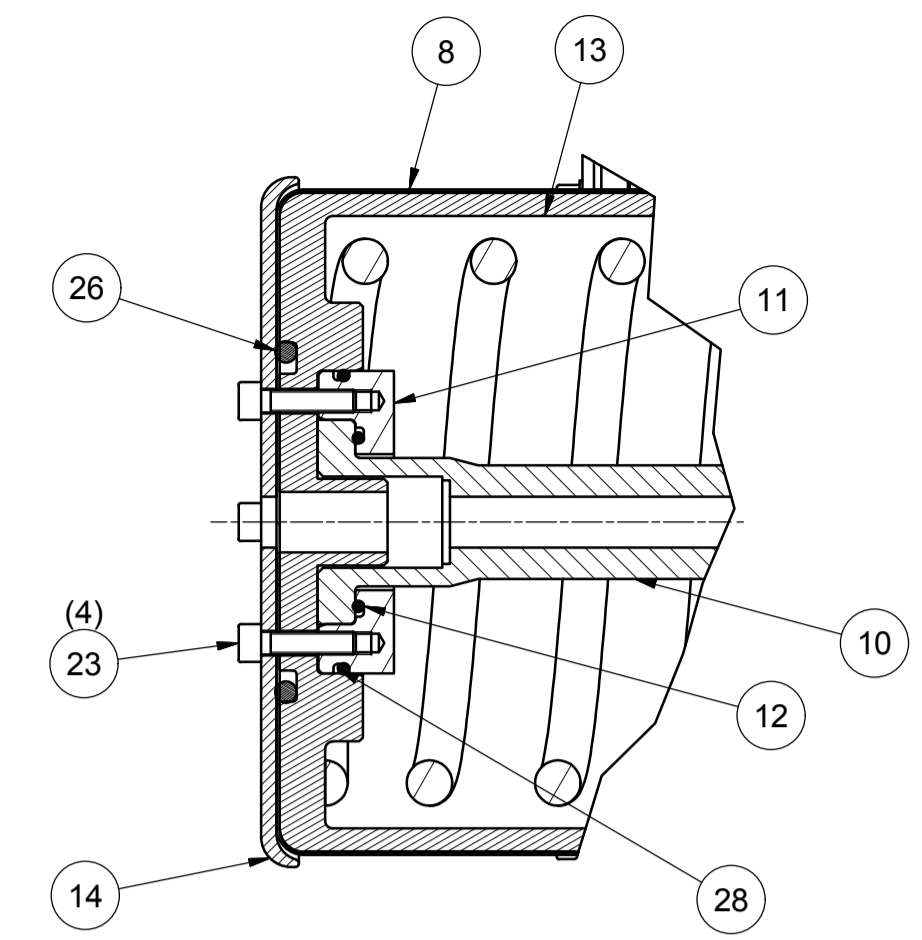

DETAIL B
(1:2)

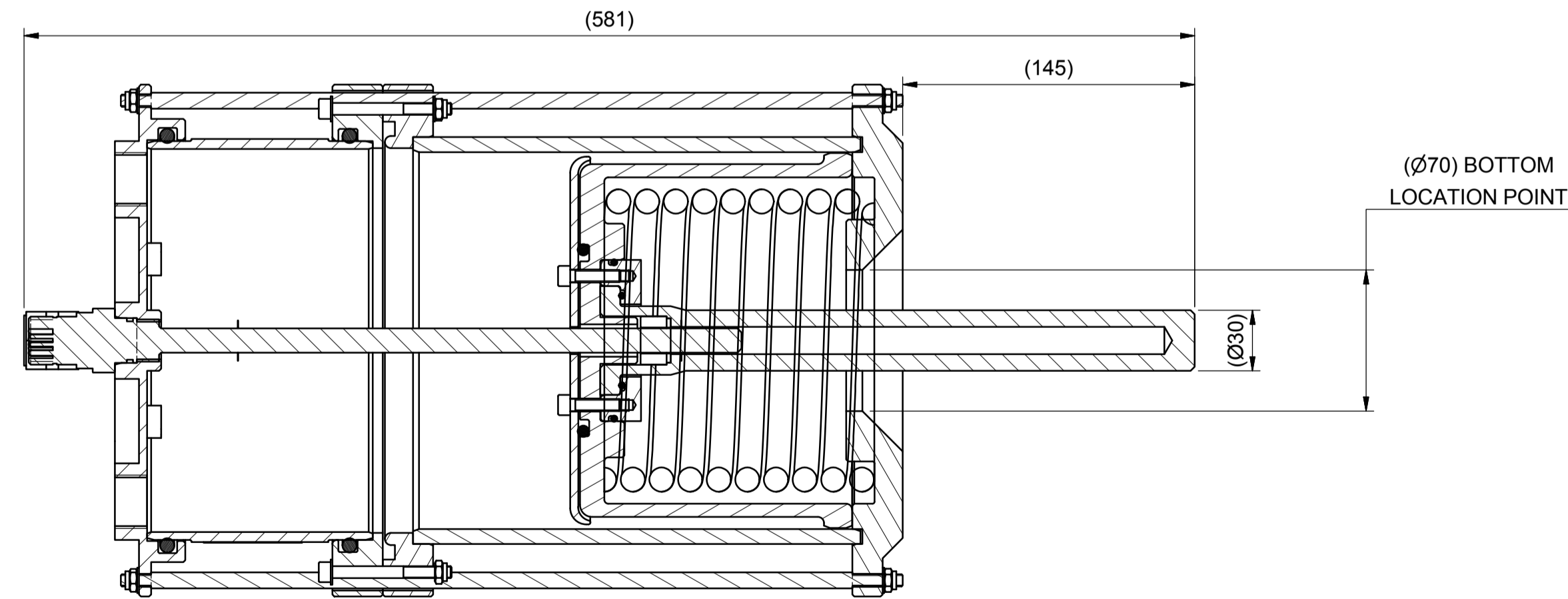
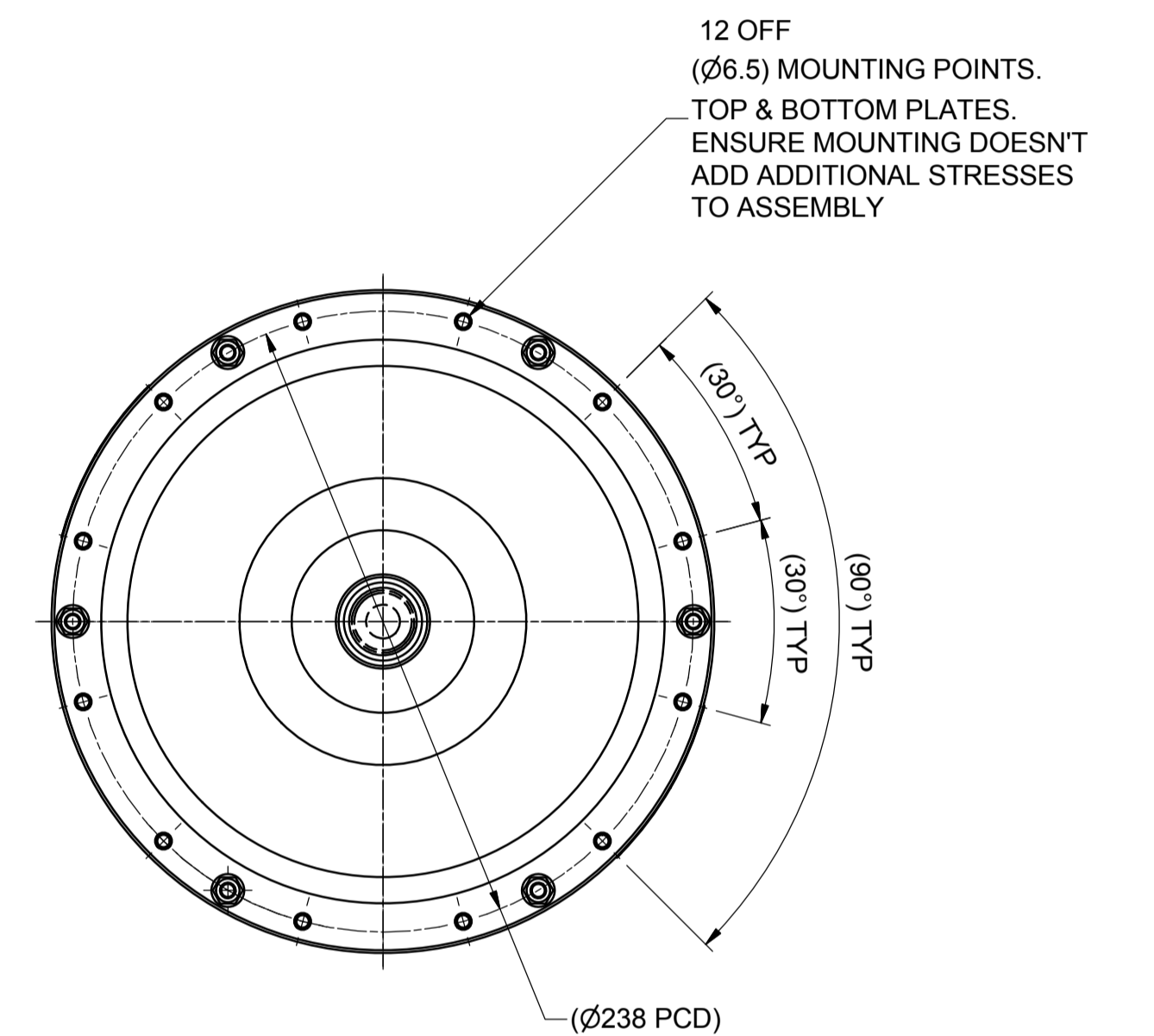
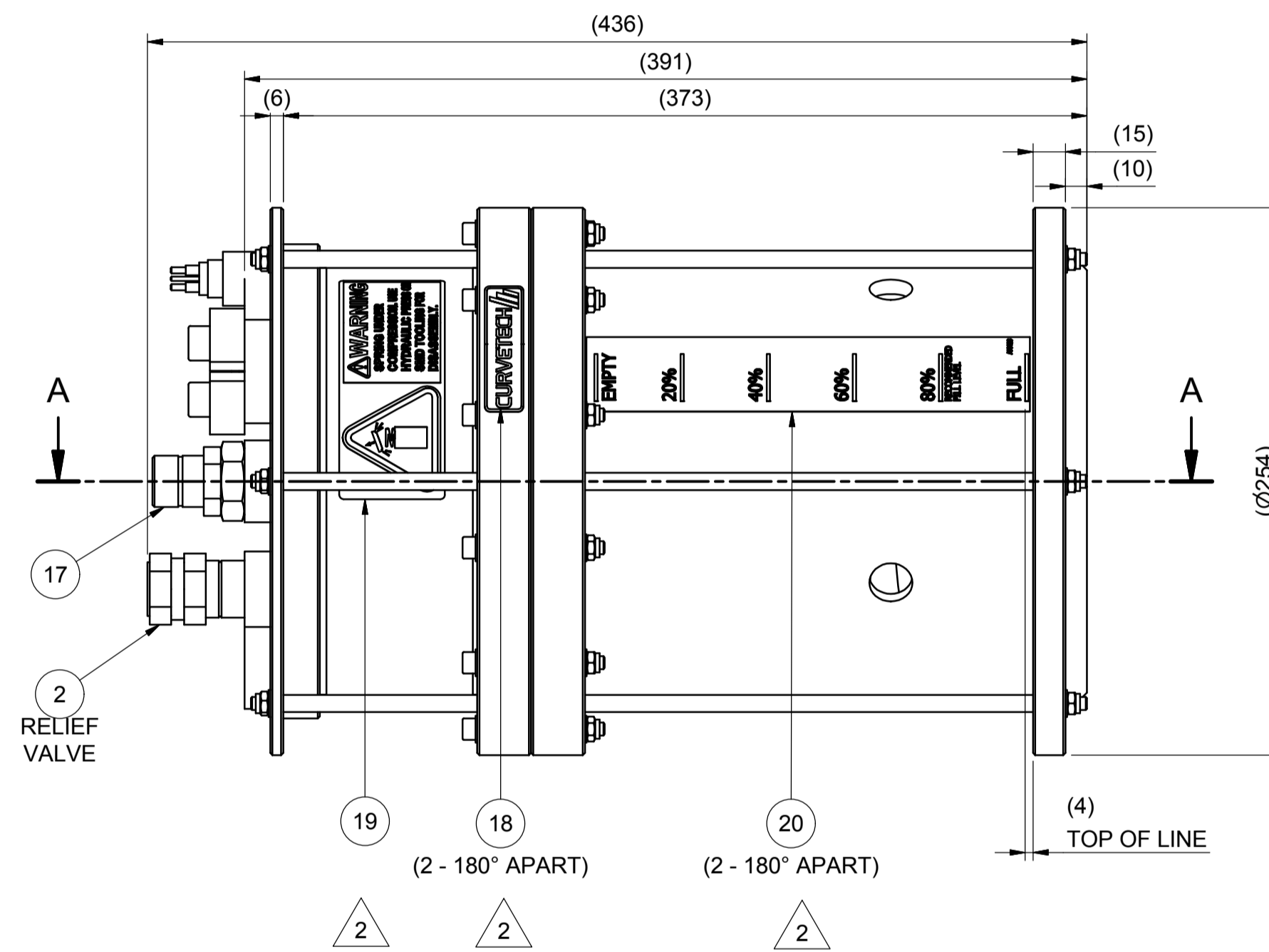
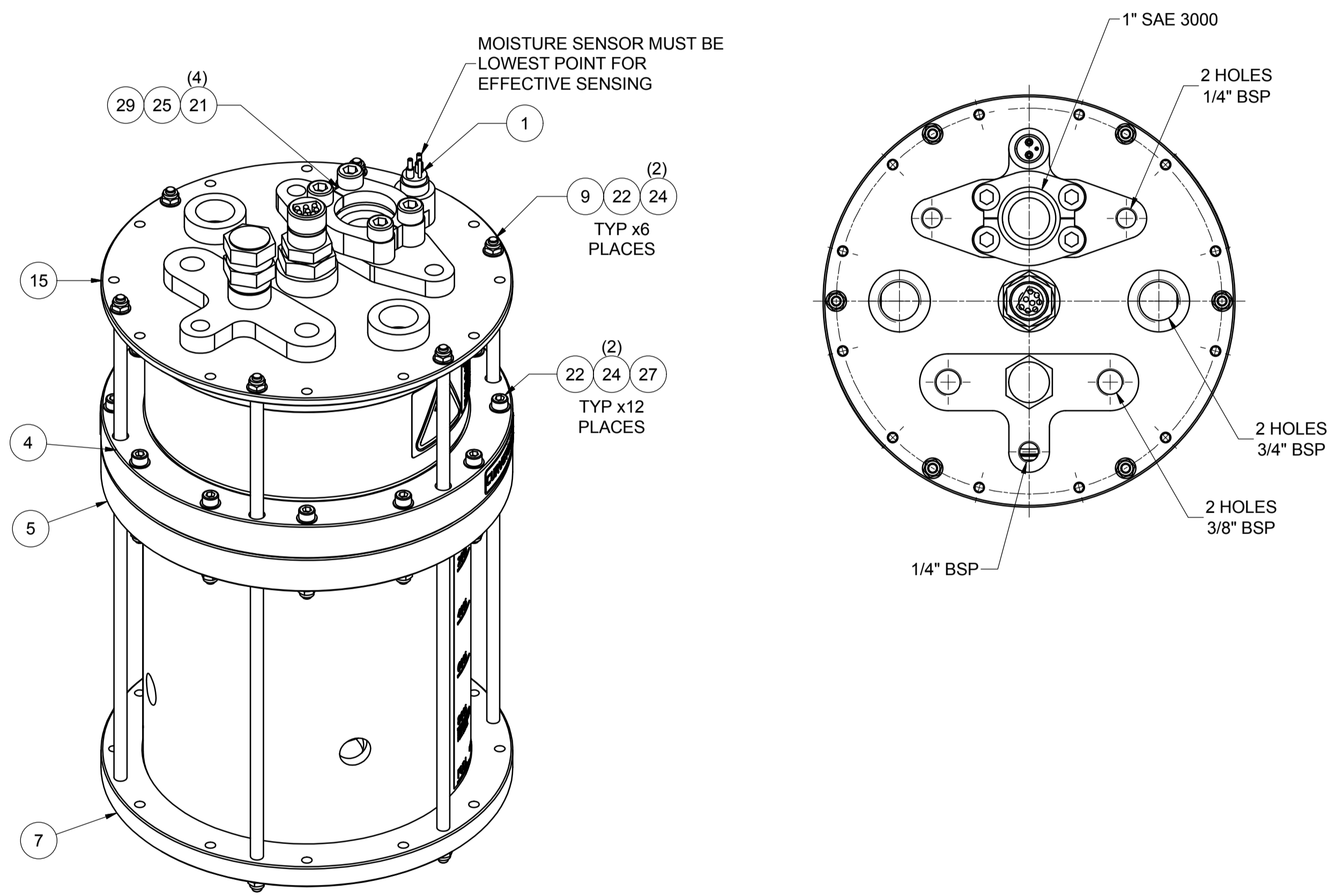

COMPENSATOR FULL
SCALE (1:2.5)

- NOTES :-
- ASSEMBLE IN ACCORDANCE WITH SMD SPECIFICATION W100.
 - APPLY MOLYKOTE GREASE ON 'O-RINGS' & APPLY AQUALUBE GREASE TO ALL THREADS.
 - BLANK ALL PORTS AFTER BUILD
 - IF IN DOUBT PLEASE ASK.

SPECIFICATION (ESTIMATE)		
WEIGHT	IN AIR	16.1 kg
	IN WATER	10.4 kg
	IN AIR WITH OIL	21.2 kg
	IN SEA WATER WITH OIL	9.4 kg
VOLUME	FULL	6 Litre
	EMPTY	0 Litre
PRESSURE	FULL	0.82 bar
	EMPTY	0.12 bar

TRANSDUCER - SEACON 5507-1508-004	
PIN	FUNCTION
1,2,3	NOT USED
4	INPUT (16.5 - 28V)
5	COMMON
6	NOT USED
7	SIGNAL (0.5 - 10V)
8	NOT USED

MOISTURE SENSOR - MCBH-2-MP-SS	
PIN	FUNCTION
1	+24V DC
2	SIGNAL

REV	DATE	CHANGE COMMENT	ZONE	DRAWN	CHECKED	APPD	DATE	EST. MASS	DIMENSIONS	SCALE	PROJECTION 3RD	TITLE
1	22 MAY 14	ITEM PF7562 REPLACED BY PA0192	-	LO	DAL	DAL	21 SEP 12	17 kg	mm	1:2.5	☉	ASSEMBLY COMPENSATOR 6L - BSP&SAE - 2-12PSI - SEACON8 - 0-10V
2	03 OCT 16	DECALS AND SPEC TABLES ADDED AND FULL SECTION VIEW ADDED.	VAR	LO	PM	MvZ						

TOLERANCES UNLESS OTHERWISE STATED	MATERIAL:-	DO NOT SCALE	DRAWING No	REV No.	SIZE
DIMENSIONS mm UP TO 100 ±1.0 100 TO 300 ±1.5 300 TO 1000 ±2.0 OVER 1000 ±3.0	N/A	IF IN DOUBT ASK	EV_4006-17	2	A1

ALL INTELLECTUAL PROPERTY RIGHTS SUBSISTING IN THESE DESIGNS ARE THE PROPERTY OF SOIL MACHINE DYNAMICS LTD. NO COPY IS TO BE MADE WITHOUT THE WRITTEN PERMISSION OF SOIL MACHINE DYNAMICS LTD. ANY PATENT APPLICATIONS, PATENTS AND / OR DESIGN APPLICATIONS, REGISTERED DESIGNS, DESIGN RIGHTS OR COPYRIGHT ARISING FROM OR CONTAINED IN THE DESIGNS ARE THE PROPERTY OF SOIL MACHINE DYNAMICS LTD. AND ALL INFORMATION MUST BE HELD IN THE STRICTEST CONFIDENCE

SMD Soil Machine Dynamics Ltd

SHEET 1 OF 1